

OTOWA SPD OLA series for Data Networks and Ethernet Applications

Universal SPD for Industrial Ethernet, Power over Ethernet (PoE++ according to IEEE 802.3bt up to 60V) and similar applications in structured cabling systems according to Class D up to 250MHz. Protection of all pairs by powerful gas discharge tubes. DIN rail mounted adapter type with sockets.



- Ideally suited for retrofitting, protection of all lines
- For use in structured cabling systems according to Class D up to 250MHz
- Power over Ethernet (PoE++ according to IEEE 802.3bt)
- For installation in conformity with the lightning protection zone concept at the boundaries from 0B-2 and higher
- EU RoHS Compliant with regulated substances

Type	OLA-1000POE	OLA-CAT6S	With indicator
SPD Class	C2 , D1		
Max. continuous operating d.c. voltage (Uc)	60V		
Nominal current (IL) Total line	1A	2A	
Impulse Durability (C2:8/20 μs) Total line/SG-PG	5kA	10kA	
Impulse Durability(D1:10/350 μs) Total line/SG-PG	2.0kA	2.5kA	
Voltage protection level line-PG (up)	≤ 500V		
Transmission Frequency	DC~100MHz	DC~250MHz	
Insertion loss	≤ 1.0dB (at 100MHz)	≤ 1.0dB (at 100MHz) ≤ 3.0dB (at 250MHz)	
Capacitance line-line	≤ 30pF	≤ 20pF	
Correspondence communication standard	10BASE-T (IEEE802.3i) 100BASE-TX (IEEE802.3u) 1000BASE-T (IEEE802.3ab)	10BASE-T (IEEE802.3i) 100BASE-TX (IEEE802.3u) 1000BASE-T (IEEE802.3ab)	
Power over Ethernet	PoE (IEEE802.3af) PoE Plus (IEEE802.3at) PoE++ (IEEE802.3bt) Alternative A, B.	PoE (IEEE802.3af) PoE Plus (IEEE802.3at) PoE++ (IEEE802.3bt) LT PoE++ UPoE HDBaseT Alternative A, B, 4-pair mode up to 120W	
Operating state / fault indication	—	blue / red	
Type of remote signalling contact	—	changeover contact	
d.c. switching capacity	—	DC30V / 0.5A	
Operating temperature range (Tu)	-20°C~+60°C	-40°C~+75°C	
Weight	approx. 60g	approx. 70g	
Enclosure material / Color	Polycarbonate/Black		
Degree of protection	IP 20		
For mounting on	35mm DIN rails acc. To EN 60715		
Connection (input/output)	RJ45 socket / RJ45 socket		
Available transmission classes	Up to Category 5e	Up to Category 6	
Pinning	1/2, 3/6, 4/5, 7/8		
Earthing via	35mm DIN rails. or M4 screw	35mm DIN rails. or M4 screw	
Test standards	IEC 61643-21		

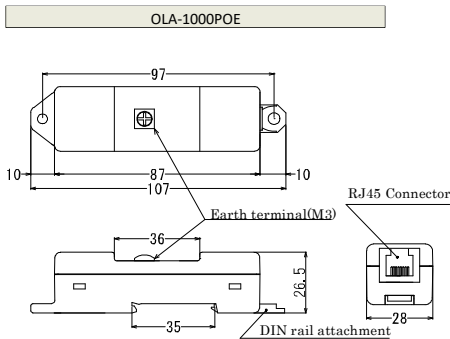

Dimension drawing

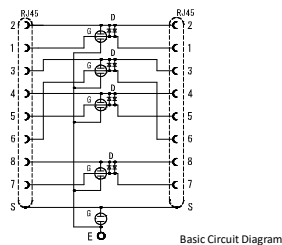

Basic Circuit Diagram

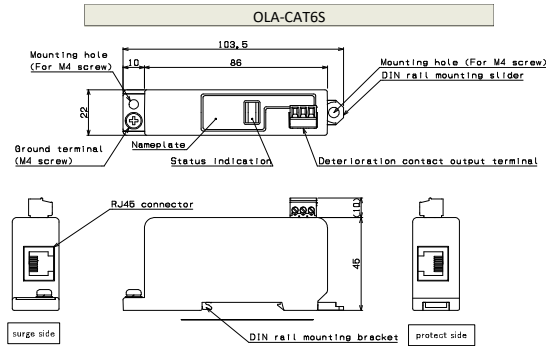

Dimension drawing

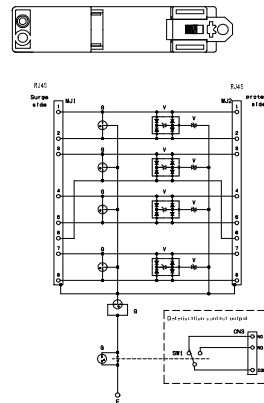

Basic Circuit Diagram

Other information



OTOWA web site



Instruction manual



Connection

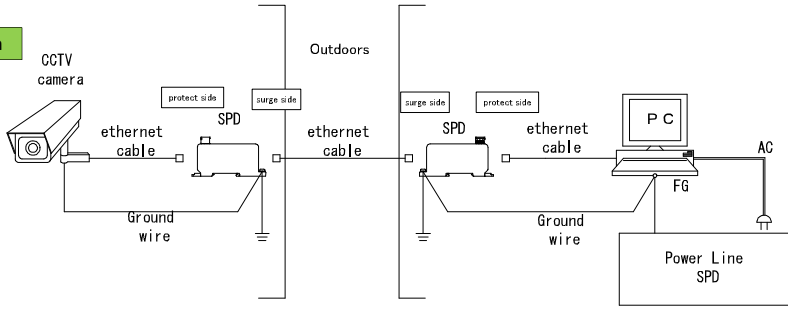

Mounting method

OLA-CAT6S

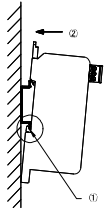

[Installation to DIN rail]

The SPD should be installed to the rail for equipment installation (35mm width of DIN standard rail)
After positioning the installation metal part (1) of the SPD to DIN rail, push the SPD into DIN rail with arrow direction of (2) until the end.

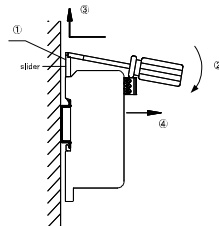

[Removing SPD from DIN rail]

(1) After inserting the flat-blade screw driver to the hole of the slider (1) and tilting it with arrow direction of (2), pull out the slider with arrow direction of (3).
(2) Pull off the SPD from DIN rail with arrow direction of (4), holding the fixing base.

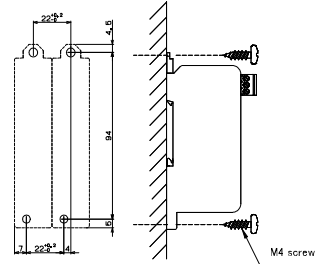

[Installation method to panel or board]

Holes must be punched or drilled on panel, and install the fixing base of the SPD by M4 screws or M4 tapping screws.

Status indication

The status of deterioration of SPD performance due to lightning surge invasion is indicated by the blue and red display ratios on the window. Indicates the progress of SPD performance degradation as a percentage of red.

- Normal
- Replacement recommendation (SPD performance is severely degraded.)
- Replace (SPD performance is lost.)
- Blue
- More than half red. (Less than half blue)
- Deterioration contact output changes

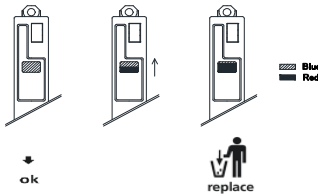

Deterioration contact output terminal

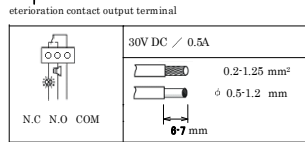
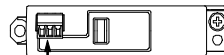

installation example



Mounting

OLA-1000POE

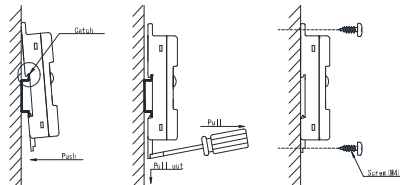

[Mounting] (DIN Rail)

[Removal] (DIN Rail)

[Fixed]

- 1) The main body is on the DIN rail with the slider down please install it.
- 2) Hook the upper hook on the back of the main unit to the DIN rail.
- 3) Push the lower side of the main unit.
- 4) When removing the slider with a flathead screwdriver push it down and pull it forward to remove the lower side of the main unit.
- 5) Remove the upper side of the main unit from the DIN rail.
- 6) For mounting on a wood board, use M4 screws in the upper and lower round holes please fix it.

Manufacturer



OTOWA ELECTRIC CO.,LTD.

5-6-20, Shioe, Amagasaki-city, Hyogo Pref. 〒661-0976, Japan

<https://www.otowadenki.com>

Agency